

Users Manual

Model HL-1 KGX

500W HF Tube Amplifier



Tokyo Hy-Power Labs., Inc.

Manual Restored by KD8MJR

Visit The New Tokyo Hy-Power User Club at:
www.thpamplifiers.com

1. PREFACE

°Before setting and operating the device, read this instruction manual carefully to keep your HL-1KGX in the best condition for a long time.

the high voltage of over 2000v is applied in the internal part of the device.

Don't touch the internal part carelessly, or you may get an electric shock and will be lethal for you. Please be careful.

°The internal electrodes of vacuum tube 4X150A/7034 may be damaged when they get a strong physical shock.

In case of transporting a long way, please pull off the vacuum tubes from the device and pack them carefully to prevent a strong physical shock to them.

2. FEATURES

HL-1KGX is a compact and light weight HF band tube type linear amplifier with maximum input of 1kW.

°Two vacuum tubes 4X150A/7034 made by EIMAC are used in parallel to get a stable operation. It boasts of maximum continuous output of 500w of 558 and CW modes.

°A large sirocco fan is used for cooling the vacuum tube. Enhancing the tenability so tube performance can be fully achieved.

°To protect the vacuum tube, warm-up time is set for 60 seconds by a delay circuit using transistors.

°This amp is interlock-switched for the safety of the equipment and its operators so as not to supply the power to the device automatically when the upper cover is taken off.

°Plate current can be watched all the time by plate current meter (IP), and plate voltage(EP), control grid current(IG) and output power(PO) can be watched by multi-meter, and each operating state can be checked easily.

3. SPECIFICATIONS

Frequency band	: 1.9 through 28MHz all HF amateur band (1.9, 3.5, 3.8, 7, 10, 14, 18, 21, 24.5, 28MHz)
Mode	: SSB, CW, (RTTY/SSTV/AM)
Output power	: 500W max. (RTTY/SSTV/AM): about a half of SSB and CW)
Driving power.	: 100W max.
Plate voltage	: DC 2KV (DC2.4KV with no RF excitation)
Plate current	: 500ma max.
Input impedance	: 50 ohm (unbalanced)
Output impedance	: 50 ohm (unbalanced)
Vacuum tubes	: EIMAC 4)(150A/7034 x 2
Semiconductors	Unijunction transistor x 1, Thyristor x 1, Diode x 31, LED x 3
Class of operation	: Class AB 1, Grounded grid
AC supply voltage	AC 100/110/117/120/200/234/240V 15/84 max. (50/60Hz)
Built-in meters	: Plate current meter: IP 600ma (full scale) Multi-meter: IG 3mA (") PO 1KW (") EP 3KV (")
Input/output connector	: M type (50-239)
Dimensions	: 284(W) x 153(H) x 375(0) mm
Weight	: approx. 18Kg
Accessories	: Control plug, Fuses(8A/200V, 15A/100V)
Cooling method	: Forced air cooling by a large sirocco fan
Power consumption	: 150VA at stand-by 1600VA at max. input

4. AC POWER SOURCE

Terminal plate is furnished at AC primary side of the power transformer to select the voltage tap. The taps have been set for 220V and/or 234/240V at the time of shipment.

In case of different AC voltage, please change the connection of harmonica-terminal according to illustrations of A-F (FIG.1-6).

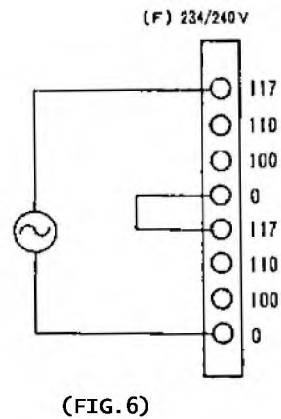
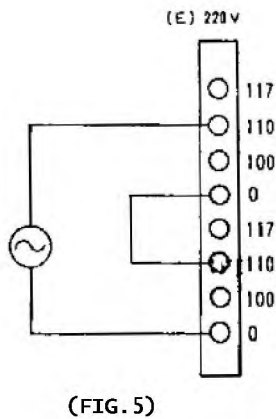
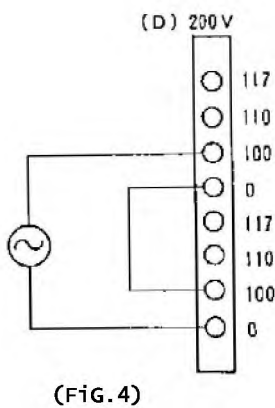
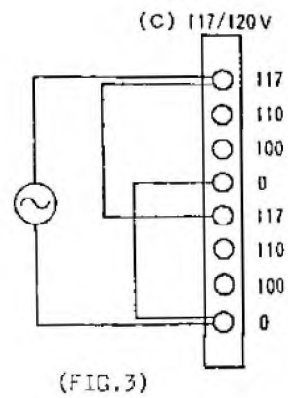
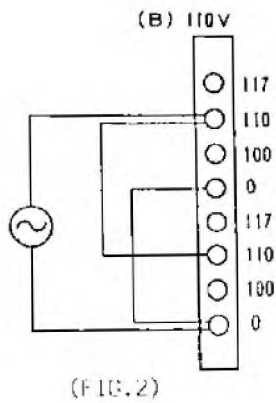
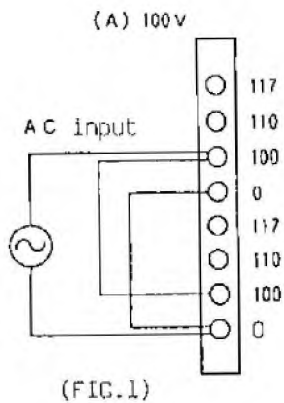

*Please check if AC Pin/Plug supplied is suitable for your country. If not, please change to the conventional AC Pin/Plug of your country.

5. EXPLANATION OF FEATURES

*FRONT PANEL

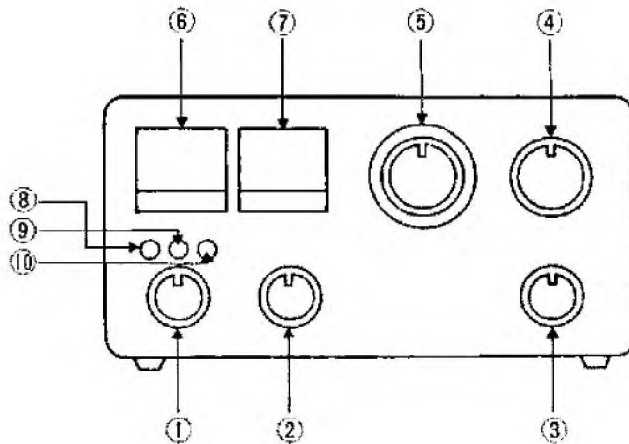

(FIG. 7)

- 1) PWR•OFF/STBY/OPER: Power on•off/Stand-by/Operate select switch.
At PWR•OFF and STBY positions, the amp is made "THRU" state, and output power of transceiver or transmitter will bypass the internal part of the device and reach antenna. (At STBY, various voltages are applied to internal parts.) At OPER position, the amp can be ON AIR.
- 2) METER : Multimeter select switch. Select IG/PO/EP indication.
- 3) BAND : Frequency band select switch. Select operation band.
- 4) LOAD : Knob for adjusting variable capacitor of the LOAD.
By adjusting this knob, effective RF power is supplied to the load.
- 5) PLATE : Knob for adjusting variable capacitor of the PLATE to the proper tuning point. 6:1 Vernier mechanism is furnished for an easy Tuning.
- 6) IP : Plate current meter. Indicates plate current of the vacuum tubes. Full scale is 600mA.
- 7) IG, PO, EP : Multi-meter. By selecting METER switch, you can read IG(Control Grid Current), PO(RF Output Power) and EP(Plate Voltage) respectively.

- 8) POWER (LED:Green) pilot lamp: This lamp lights at STBY and OPER positions of switch (1) and indicates POWER is ON.
- 9) WARM UP(LED:Yellow) pilot lamp: Turning Power Switch(1) to STBY position, this lamp lights when warming up of heater is completed. (It takes approx. 60 seconds.)
- 10) ON AIR (LED:Red) pilot lamp: This lamp lights when the amp is ON AIR.

*REAR PANEL

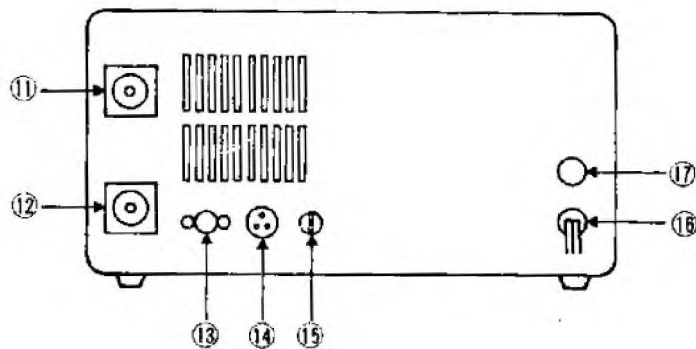

(FIG.8)

- 11) OUTPUT(ANT) : Output terminal or linear amp.
Connect load(antenna or dummy load).
- 12) INPUT (TX) : Input terminal of linear amp.
Connect cable from antenna terminal of transceiver or transmitter.
- 13) GND : Ground terminal.
- 14)CONTROL : Terminal for remote control of RX to TX and ALC output.
By connecting cables between control terminals of transceiver or transmitter and the amp, changeover from RX to TX can be made automatically.
Three cables(vinyl coated wire etc.) for STBY/ALC/EARTH are required to connect with transceiver.
- 15)ALC : Adjusting knob for ALC output of control terminal Adjust it according to the exciting power level of transceiver or transmitter.
- 16)AC POWER : AC power cord.
- 17)FUSE : 15A(at AC 100V). For AC 200V replace with 8A fuse.

*INTERNAL VIEWS

°Upside of the chassis

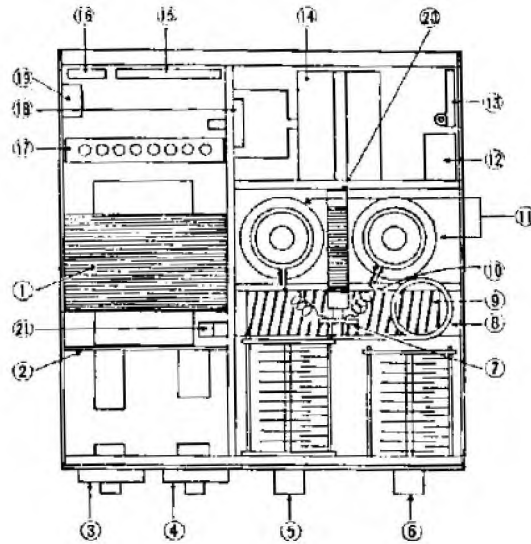

(FIG. 9)

- | | |
|------------------------------------|--|
| 1)POWER TRANSFORMER | 16)WARM-UP TIMER UNIT(Setting time 60 sec.) |
| 2)HIGH VOLTAGE RECTIFIER UNIT | 17) AC SOURCE TERMINAL PLATE |
| 3)PLATE CURRENT METER | 18)CONTROL GRID BIAS VARIABLE RESISTOR |
| 4)MULTI METER | 19)INTERLOCK SWITCH(AC SOURCE SIDE) |
| 5)TUNING VARIABLE CAPACITOR | 20)PLATE RF CHOKE COIL |
| 6)LOADING VARIABLE CAPACITOR | 21)INTERLOCK SWITCH (HIGH VOLTAGE SIDE) |
| 7)COUPLINC CAPACITOR (DC BLOCKING) | |
| 8)TANK COIL (14 - 28MHz) | |
| 9)TANK COIL (1.9 - 10MHz) | |
| 10)PARASITIC OSCILATION SUPPRESSOR | |
| 11)VACUUM TUBE (2x EIMAC 4X150A) | |
| 12)ANTENNA RELAY | |
| 13)RF POWER DETECTOR UNIT | |
| 14)COOLING BLOWER | |
| 15)12V CG.SG POWER SUPPLY UNIT | |

Bottom of the chassis

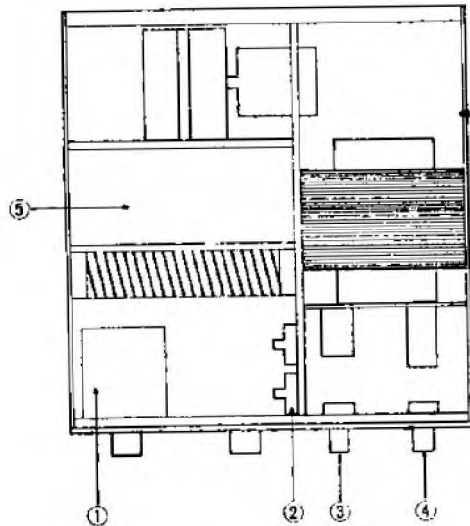

(FIG.10)

- 1) BAND SELECT SWITCH
- 2) FIXED CAPACITOR OF PLATE SIDE
- 3) MULTI METER SELECT SWITCH
- 4) PWR/STBY/OPER SELECT SWITCH
- 5) AIRDUCT AND RF INPUT CIRCUIT

6. OPERATION

- 1) Connect RF jumper cables and power cord according to FIG. 11

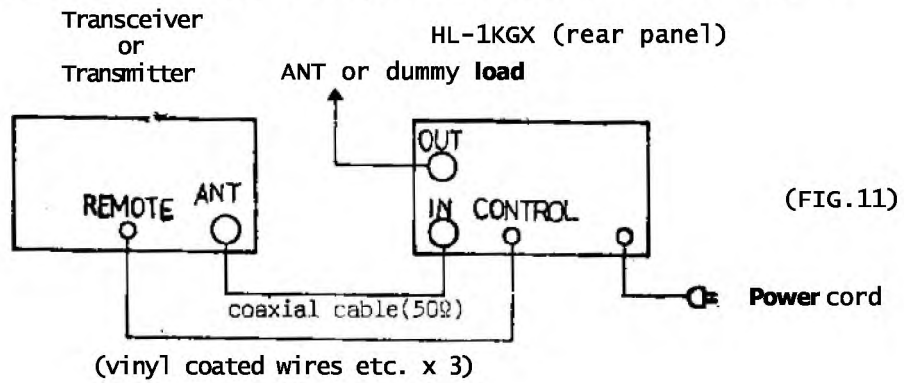

(FIG.11)

*Connection of control terminal
(Control socket viewed from outside of the chassis)

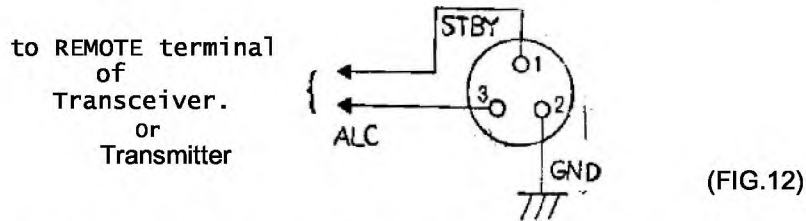

°Set the cable from STBY terminal to the remote control terminal of transceiver or transmitter which gets grounded at transmitting.

°Power amplification state" cannot be made without connecting STBY terminal.
A simple transmitting test without wiring Send/Receive remote control can be made by grounding STBY terminal.

- 2) Check if the BAND select switch is same as that of transceiver or transmitter.
- 3) set the Knobs of variable capacitors for Plate and Load to each corresponding position beforehand (on 50ohm load) according to the following diagram.

BAND	1.9	3.5	3.8	7	10	14	18	21	24.5	28
PLATE	5.5	3.0	7.5	3.5	2.5	4.5	6.0	7	8.2	9
LOAD	7	3.5	6	4.5	5	5.5	6.7	7.3	7.8	8.3

- 4) Turn the POWER switch on (STBY position) and wait for approx. 60 seconds until WARM-UP pilot lamp lights. Then, switch to OPER position and make your transceiver. or transmitter on air. ON AIR pilot lamp lights and idling plate current should run approx. 100mA.
Adjust carrier level of Transmitter to get an IP of Approx. 300ma
- 5) Always adjust Plate Variable capacitor to make Output power meter (PO) indication to increase and IP to dip.
- 6) Adjust Load variable capacitor to maximize Po meter Indication.
- 7) Now increase carrier output power Level of transceiver transmitter to Get an IP of 500ma.
At this time, adjust each Load knob and Plate Knob Alternately to maximize the output power.
To achieve a Clean output wave form, Turn Load knob Clockwise slightly to decrease PO (Output power) by 5-10% from the maximum point and set the Plate knob always to get IP (Plate Current) dipped.
*Try to finish this adjustment within a minute'
If it takes longer, please let the device idle for a minute.

- 8) Operate the device with adjusting ALC knob on rear panel to proper operating voltage according to the output of the transmitter. Set the ALC knob at the point where IG meter rarely deflects and Power meter or IP indication is about to decrease slightly from the peak.
Be sure to check the output power is not exceeding 500w after the adjustment.
To transmit a clear and not a distorted wave, use ALC always in SSB mode operation.

7. MAJOR CIRCUITS

1) RF Input Circuit

RF power sent from transmitter or transceiver to input terminal goes through relay contact and attenuator input circuit, then reaches cathode of the vacuum tube 4x150A/7034.

2) Power Amplification Unit (PA.Unit)

PA. Unit is a grounded grid linear amplifier consisting of two vacuum tubes of 4x150A/7034 connected in parallel.
-55V voltage is applied to the control grid to run approx. 200mA of IP for two tubes when no driving .
Approx. +350V voltage is applied to the screen grid.
At receiving state, control grid voltage becomes -140V to cut off the tube.

3) Output Circuit

The output power of vacuum tubes goes through a parasitic suppressor R1/R2 and also coupling capacitor C1, and then, goes into Pi type output tuning circuit.
This output circuit covers from 1.9 through 28MHz by separating to 9 bands. The Band-switch switches both taps of tank coil and additional fixed capacitors to Plate tuning and Load tuning as well.
Power from output tuning circuit goes through relay RL2b and directional power meter unit, then reaches output terminal J2.

4) Directional Power Meter Unit

RF power detected by toroidal core type current transformer is rectified by high efficiency schottky diode D29 and then, drives the power meter.

5) ALC Circuit

A part of driving input signal is rectified by diode and supplied to ALC terminal as a negative ALC voltage.
By connecting the ALC terminal and ALC input terminal of transceiver or transmitter to make feedback, it will effectively prevent increasing distortion caused by overdrive.

6) Heater Warming-up Unit

Time constant by capacitors and resistors of this circuit is set approx. 60 seconds to enough warm up vacuum tubes 4X150A beforehand.

Relay (RL1) is driven by 1 pc, each of uni-junction transistor and thyristor.

7) Power Supply Circuit

High voltage of AC 850V at secondary of power transformer is rectified by voltage doubler circuit of eight rectifying diodes to get the DC voltage of 2400V, which is then supplied to plate of the vacuum tubes.

Two heaters are connected in series to accept 12V line of power transformer and this AC voltage of 12V is shared with heater warm-up circuit (used after being rectified).

Besides, DC power supplies for screen Grid of 390V and for control grid bias of -55V to -140V stabilized by zener diode are built in the unit.

8. CAUTION

1) Impedance

When you **operate the device, please always connect, as a load, a well-adjusted antenna** or a dummy load of 50ohm. In case that the antenna **impedance is** extremely off from 50 ohm, please use the impedance matching circuit such as an antenna coupler etc. If you transmit under **no load or** mis-matching condition, the expensive vacuum tubes may be deteriorated in a short time.

2) Place of Installation

Install the device at well-ventilated and dry places where it is not exposed to the direct rays of the sun, as the device radiates plenty of heat and uses a high voltage.

3) AC Power Source

The device is designed to operate from AC 100-120V or AC 200-240V by selecting the connection of the internal terminal board.

Be sure to check the connection of AC power terminal board near **the** power transformer.

4) If you open the cover:

a) to check the internal part of the device, please pull the AC power plug off and check that the high voltage has been discharged to prevent yourself from being electrocuted.
(Be sure to check the EP = 0(zero)V on the multi-meter.)

b) don't touch or trim the directional power meter and control grid bias adjustable resistor VR2 as they have been already adjusted.

5) To protect the vacuum tubes the 4X150A and chimneys have been packed separately from the device.
Do not connect the AC cord before setting the vacuum tubes.

*Setting up the vacuum tubes and chimneys.

[1] Remove upper cover and upper shield cover.

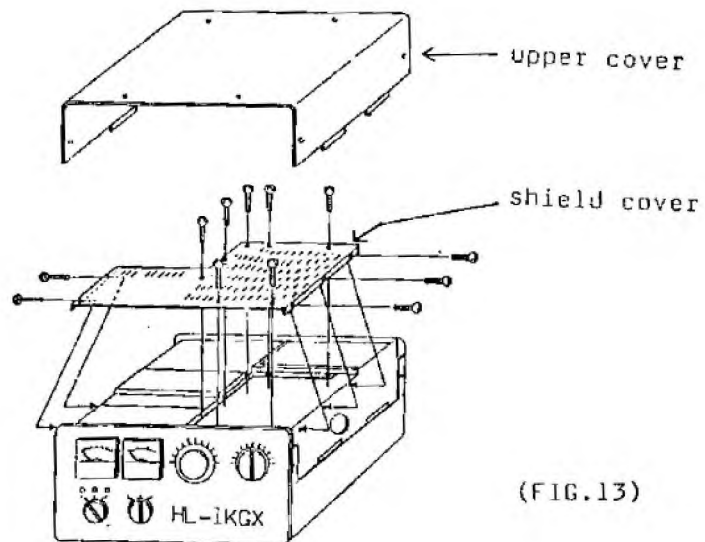

(FIG.13)

- [2] First, set the chimney and vacuum tube into the socket of inner side according to FIG.14.

(Place the tube so that the mark of notch faces the front, and raise the plate band for an easy tube installation.)

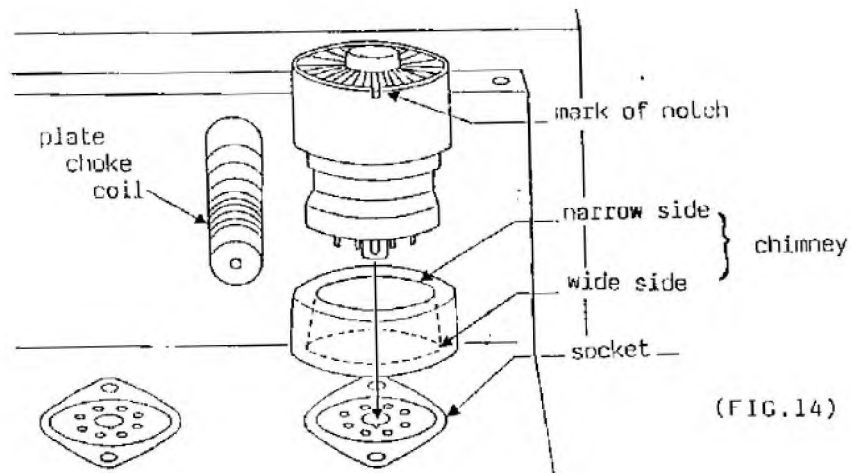

(FIG.14)

- [3] Then, set the plate band and tighten the screws by screw-driver approaching through side panel according to FIG.15.

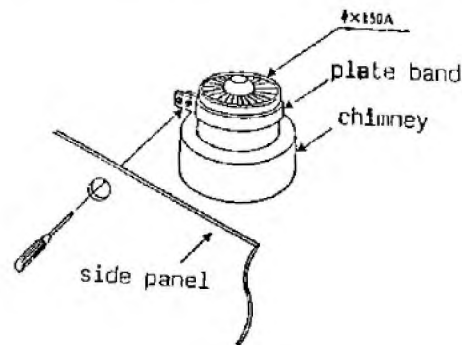

(FIG.)5)

- [4] As the same way, set the vacuum tube of the outer side.

- [5] Set the shield cover and upper cover.
(The shield cover must be always used.)

The preparation is now finished. (documentation provided thpamplifiers.com for free)

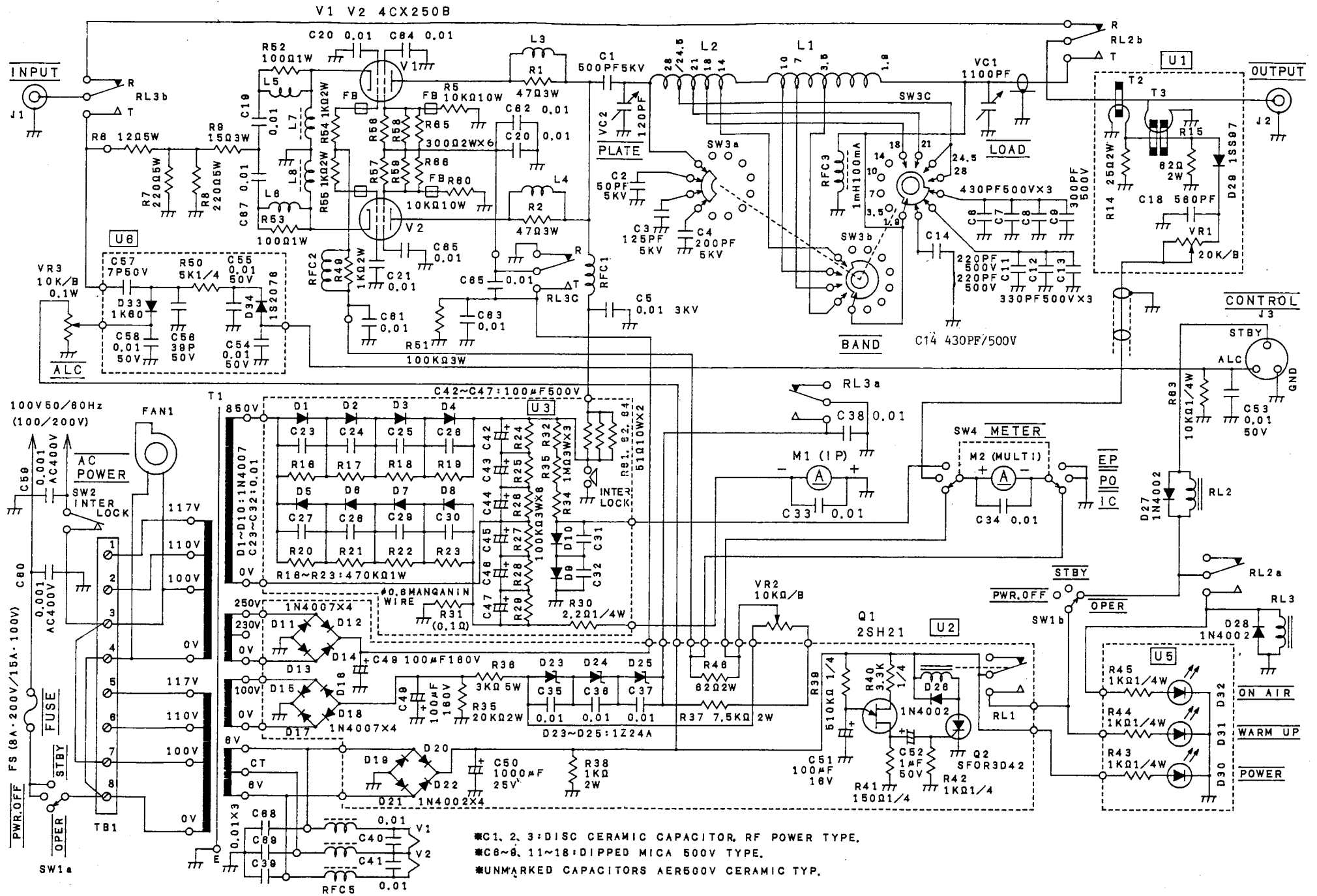

*C1, 2, 3: DISC CERAMIC CAPACITOR, RF POWER TYPE,
 *C8-8, 11-18: DIPPED MICA 500V TYPE,
 *UNMARKED CAPACITORS AER500V CERAMIC TYP.